

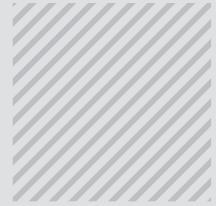

IOM MANUAL

Air Handling Units



AHU

OPERATION AND
MAINTENANCE MANUAL

COLAIR.NET.AU



**AIR HANDLING UNIT
IOM MANUAL**

CONTENTS

02 QUALITY AIR MOVEMENT

03 GENERAL SAFETY GUIDELINES
INTENDED USE
WARRANTY

04 LIFTING AND RIGGING

06 MIXING BOX

07 FILTERS AND FRAMES

08 COIL SECTION

09 FAN SECTION

10 CONDENSATE DRAIN

11 JOINING SECTION

12 SERVICE LIGHTS

13 PLATE HEAT EXCHANGERS

14 OPTIONAL ACCESSORIES

15 UNIT IDENTIFICATION

17 AHU CASE SIZE BY DESIGN
AIR FLOW RATE
AIR FILTER CONFIGURATION

18 COOLING PERFORMANCE

19 HEATING PERFORMANCE

20 SINGLE PHASE FAN WIRING

21 THREE PHASE FAN WIRING

Operation and Maintenance Manual

**COLAIR IS COMMITTED TO
PROVIDING COMFORT AND
ASSURANCE WITH A CERTIFIED
AND QUALITY SOLUTION FOR
YOUR NEXT PROJECT OR DESIGN.**

QUALITY AIR MOVEMENT

Air Handling Units are customisable, designed and built for Australian, New Zealand and Asia Pacific conditions. Modular units can be used in both indoor and outdoor installations.

Colair modular Air Handling Units have non-cold tracking options available to suit your thermal bridging requirements. Manufactured in accordance with EN1886:2007 and built to comply with Australian Standards AS/NZS 3666, with particular attention to access for cleaning and maintenance, Colair modular Air Handling Units have all the features and accessories your project requires.

Colair modular Air Handling Units are constructed using aluminium penta-post frames with a 50mm polyurethane filled panel, and a thermally broken construction to prevent cold tracking. Panels can be removed without affecting the structural integrity of the unit. Access panels can be sized to suit the individual requirements of the project with hinged doors opening outward for negative pressure applications and inward opening doors for positive pressure applications.



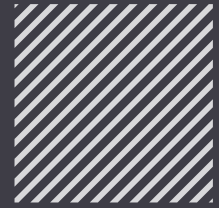

GENERAL SAFETY GUIDELINES

Colair Air Handling Units are a custom designed and built product to suit particular project requirements and are supplied in accordance with the approved construction drawings.

This operation manual is intended for use by rigging sub-contractors, installing contractor and service personnel working on the Colair units. Failure to comply with any of these requirements could result in serious damage to the equipment, the property in which it is installed, as well as severe personal injury or death to themselves and people at the site. It is expected that the personnel installing or servicing the Colair units are qualified accordingly to enable the individual to perform the assigned tasks properly and safely. It is essential that, prior to performing any task on this equipment, this individual shall have read and understood the on-product labels, this document and any referenced materials. The individual shall also be familiar with and comply with all applicable industry and governmental standards and any regulations pertaining to the task in question.

During rigging, installation, operation, maintenance and service of the Colair units, an individual may be exposed to certain components or conditions including, but not limited to: heavy objects, materials under pressure, rotating components and electrical voltage. Each of these items has the potential, if misused or handled improperly, to cause serious damage to property, equipment or personnel. It is the obligation and responsibility of the installer and operating service personnel to identify and recognize these inherent hazards, protect themselves, and proceed safely in completing their tasks.

INTENDED USE

Colair units are manufactured to create a desired indoor air quality, air temperature, humidity or to filter normal or contaminated air. Colair units are suitable for both indoor or outdoor operation, in a temperature range from 0°C to 40°C. Any operation outside of these conditions must be agreed in writing by Colair Pty Ltd.

Any additional changes to the supplied equipment of third party components will be the responsibility of the individual or company whom installed them.

WARRANTY OF THE PRODUCT

Please refer to warranty policy provided.

LIFTING THE AIR HANDLING UNITS

Unit weights and dimensional information is found on the packing details. Please exercise extreme caution when lifting or moving the Colair unit with a forklift. Do not exceed the weight or height limit of the forklift

Never allow the forklift forks to make contact directly with the side or the bottom panel of the Colair unit.

Make careful consideration of the unit's centre of gravity and distribute the weight equally on both forks. Test load to see if the weight is equally distributed before continuing the lift. Do this by lifting the unit a few centimetres off the ground level and checking stability before lifting or transporting the unit.

RIGGING WITH A CRANE

Unit weights and dimensional information is found on the packing details. Personal SAFETY when lifting, installing or working on equipment. Always adhere to safety codes and guidelines. PPE is required, ensure safety goggles, work gloves, work boots and protective clothing is worn.

All Colair units are manufacturer lifting points, they positioned at a variety of points along the base frame. Please note the Colair units should be lifted into position using soft slings and NOT chains. The use of chains may cause damage to the exterior panels, pipe work or accessories installed on the unit and will not be covered under warranty.

Where units have to be craned into position, installers must check unit weight is within the safe tolerance of the working capacity of the crane lift and reach.

Preparation for lifting the unit, there is a requirement for spreader bars, as you would do with lifting and air conditioning equipment to ensure no crushing effect on the Colair unit.

When lifting equipment never stand under the load or lift equipment on to roof areas in windy conditions. Only lift when weather conditions are favourable for the scope of works undertaken.



LIFTING POINTS



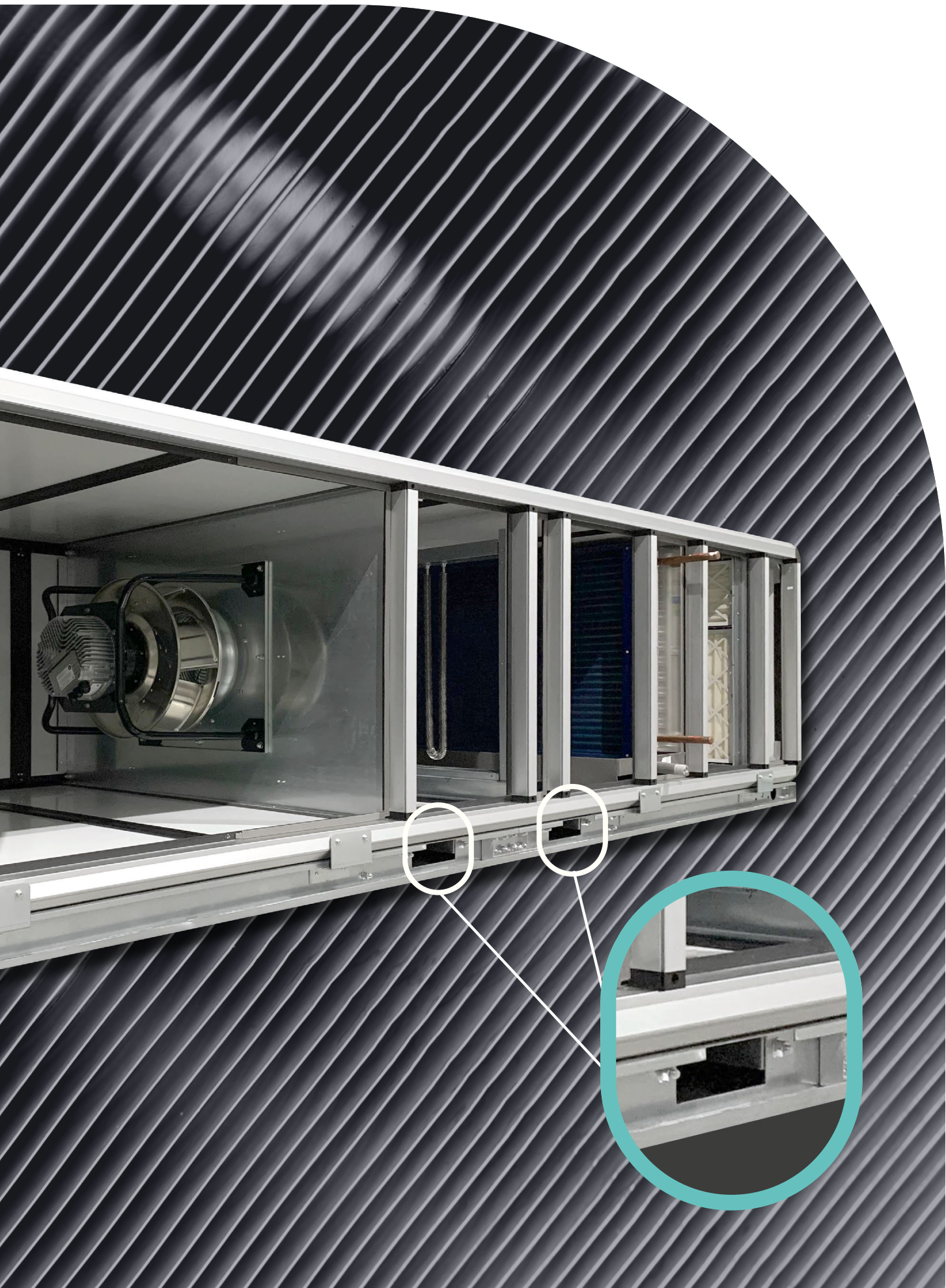

MIXING BOX



1. The mixing box section can be supplied with multiple sets of dampers. Dampers supplied are constructed from high quality material and components.
2. Dampers can be supplied with handles to manually operate the dampers. A lock-nut is available on the handle to fix the position of the damper opening should it be manually operated. A lock-nut is available on the handle to fix the position of the damper opening should it be manually operated.
3. Should the damper require to be actuator operated, the handle can be removed and be fixed with the damper actuators.
4. Dampers do not require any heavy maintenance. Cleaning of foreign material is highly recommended to ensure correct and smooth operation.
5. Internal moving parts of the damper maybe require monitoring to ensure the correct function throughout the life of the AHU.
6. Periodic cleaning of the mixing box as conditions require will ensure correct operation and prolong lifespan.
7. Dampers with rubber seals on the blades will be required to be checked and cleaned quarterly

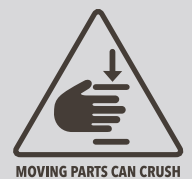

MOVING PARTS CAN CRUSH

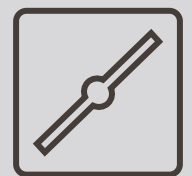

VOLUME CONTROL DAMPERS

FILTERS AND FRAMES

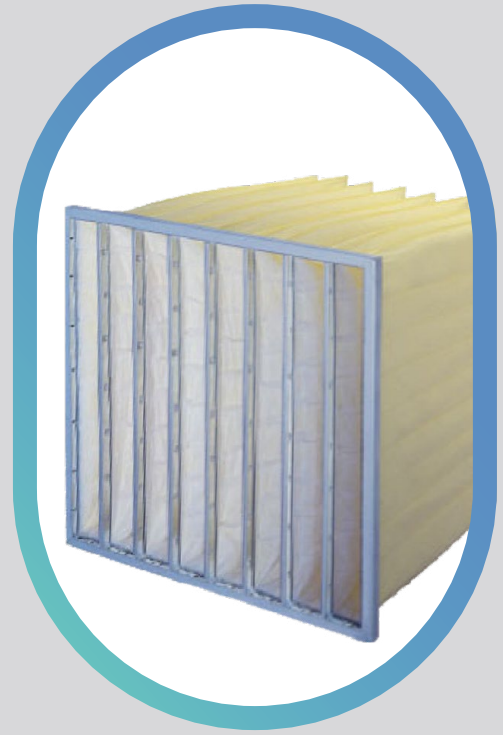

1. The filter frames are generally supplied as galvanized steel frames unless otherwise requested. It is internally lined with a gasket. When the filter is compressed on the gasket, it provides a seal for the filters to minimize air from bypassing the filters. Four metal clips are used on each sides of the filter frame to hold and compress the filters on to the filter frame. Each clip shall be properly engaged onto the filter frame after each service of the filters.
2. There are the possibility of two standard of the shelf filter frame sizes. One being full size and the other in half size. These standard sizes are widely used in the general filter industry. The full size filter actual dimension is 595x595mm while the half size filter actual dimension is 290x595mm.
3. The synthetic fibre filter casing thickness is 47mm while the bag filter casing thickness is 21mm with an extended surface bag length of either 380mm or 530mm.
4. The synthetic fibre filter is disposable type and needed to be serviced based on operational requirement. The synthetic fibre filter may deform over time requiring replacement
5. A lack of maintenance might cause clogging on the filter and will subsequently reduce the AHU air flow rate.
6. The bag filter should be replaced in accordance with the site requirements.
7. The bag filter is used to filter fine dust that might not be visible thru normal vision. If not serviced regularly, could cause reduction in AHU air flow rate. If not serviced for a period of time, the risk of damage to the integrity of the panel structure of the AHU due to high negative section pressure created by the fan due to clogged filters.
8. Filters should be monitored by an appropriate device to determine when replacement or cleaning is required.
9. The recommended final pressure drop limit shall be 200Pa for synthetic fibre filter and a limit of 300Pa limit for bag filter.

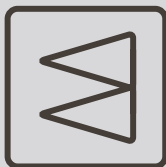

FILTERS

COIL SECTION



1. The coil section will consist of finned tubes heat exchanger (cooling and or heating coils) with a drain pan.
2. The finned tubes heat exchanger is made of aluminum fins mechanically bonded to a matrix of staggered copper tubes. The casing of the heat exchanger is made of thick aluminum sheet. The waterdistribution header to the heat exchanger is from copper material.
3. The finned tubes heat exchanger is a non-rotating component and does not require any part replacement. Should air handled by the AHU be of a corrosive nature the fins may deteriorate over time. Fin protection coating is highly recommended for such operation conditions.
4. Heat exchangers will require periodic cleaning to ensure operating efficiency and longevity. If coils have been treated, periodical inspections of the corrosion applied is recommended during the cleaning process. The corrosion treatment may need to be re-coated depending on the recommendations from the product manufacture applied. Details can be found on the label adjacent to the coil panel.
5. The drain pan is made from SS304 material in accordance with the AS3666. To ensure the best indoor air quality possible, cleanliness of the coil and drain pan is required. Regular maintenance and cleaning will be required.
6. During the regular service visits check obstructions in the drain pipe of the AHU.

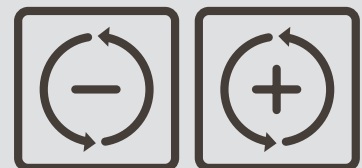

CHILLED WATER COIL

HOT WATER COIL



RUN AROUND COIL

DX COIL

FAN SECTION



1. Colair fan(s) supplied in the AHU are as per the approved drawings provided. Colair fan options include but are not limited to, direct driven centrifugal DIDW, AC and EC Plug fans.
2. AC Plug fans must be operated with a variable frequency drive (VFD). Without this the warranty will be null and void.
3. For DIDW fans (belt driven fans) the motor can be coupled to a variable frequency drive (VFD) as required.
4. All wiring connections shall be properly terminated and all conduits shall be sealed properly to ensure no air channelling through the conduit that might cause moisture ingress.
5. The power supply cable connection shall be ensured correct as per the wiring label on the motor nameplate. The motor can be coupled to a variable frequency drive (VFD).
6. When operating with VFD, the fan speed shall be adjusted gradually to achieve the air flow rate required. The motor electrical current limit shall be properly pre-set on the VFD as safety precaution.
7. For safety and the correct operation the fan should not exceed the recommend rotation speed.
8. Where belt driven fans are installed, it is important that the belts are inspected for damage or fraying and replaced as necessary. Belt tension should be checked and adjusted periodically using a belt tensioner.
9. Any works to the fan section shall only be carried out when the unit is not operational and it is safe to enter the environment. Electrical isolation and lock out procedures as per relevant codes of practice.
10. The fan assembly should be checked regularly for its vibration level. The maximum vibration speed in radial direction must not exceed 4.5 mm/s to monitored at the bearing or bearing housing of the fan or motor. For fans with an impeller diameter up to 315mm a vibration speed of up to 7.1 mm/s is acceptable. When exceeding the permitted vibration values, it is mandatory to rebalance the entire rotating assemble unit in accordance with DIN ISO 1940-1.
11. After a long period of operation during which the grease keeps its lubrication performance (30,000 h for standard applications), a bearing change may be required. For standby AHU, during periods of long idling periods, the fan should be put to operate on regular intervals. This is to prevent the bearings from mechanical load and the avoid ingress of moisture.
12. The vibration isolators used are a restrained type and therefore secured from any type of potential movement in any direction. As it is restrained in design, there is no need for any bracket or bolt to be loosened or adjusted before commissioning the AHU or during any time of the fan operation.
13. The vibration isolators are generally maintenance free. However, during service visits it is recommended to periodically check the mounts for any signs of any cracks to avoid mechanical failure from occurring, that could cause damage to the fan assembly.
14. The canvas connection between the fan and the air inlet structure should be periodically checked to ensure integrity. If damaged, a replacement will be required.

CONDENSATE DRAIN



1. Each condenser drain must be equipped with a U-trap.
2. The following conditions are essential for correct operation.
3. At each drain a U-trap must be connected.
4. Several drains may not be connected to one U-trap.
5. The water from the U-trap must run in a funnel.
6. Before starting, fill the U-trap with water.
7. The heights H, J and L can be determined from the maximum negative pressure (p) and maximum pressure (p) in the section of the U-trap or be determined by the information on the technical data sheet as follows:

Negative Plenum Pressure

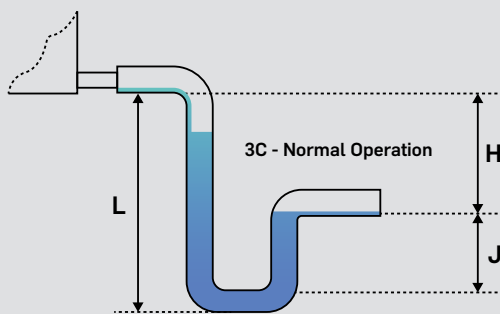

$H = (1'' \text{ for each } 1'' \text{ of maximum negative static pressure}) + 1''$

$J = \text{half of } H$

$L = H + J + \text{Pipe Diameter} + \text{Insulation}$

Positive Plenum Pressure

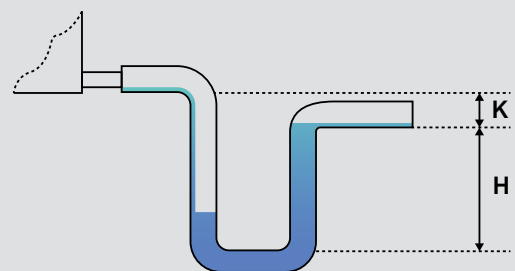

$K = \text{min. } 1/2''$

$H = 1/2'' \text{ plus maximum total static pressure}$



U TRAP

JOINING SECTION

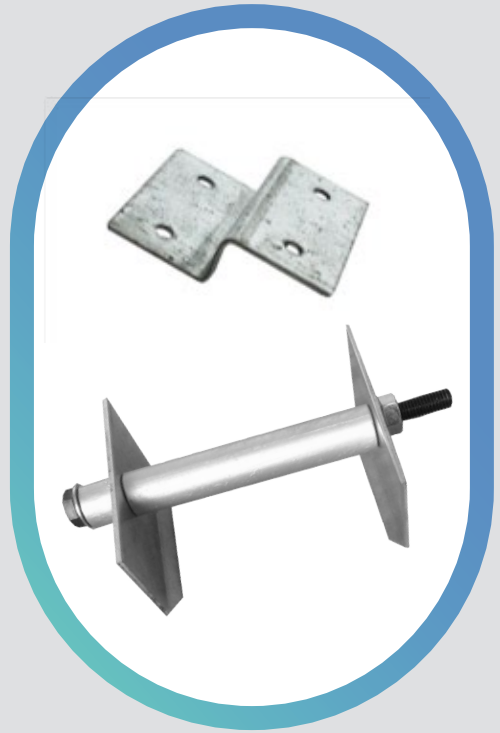

1. In Colair AHU, unit base support is used for units that have dimensions more than 2000mm (height) and 3000mm (width) on either side of unit. For small units, the profile is fastened to the based with nutserts and bolts.
2. When the section joint is required to be connected on site, installers need to ensure the sections are joined properly.
3. Unit base support need to be removed in the unit section area before attach the unit section.
4. The unit base support that need to be removed has yellow sticker with label "please remove this part before installation".
5. When the unit base support has been removed, join the multiple sections as aligned as possible on all sides.
6. Once the unit is joined as close as possible, place all gaskets provided between the profiles and use the bracket provided to close the gap by tightening the bolts.
7. Once together, insert the bolt through the predrilled hole and fasten with the nut on the other side.
8. Tighten until the unit is positioned correctly.
9. Do not over tighten, this can damage the panel and air tight integrity.
10. After the process is complete, screw the section joint (red colour) on the unit profile correctly.



Unit Base Support

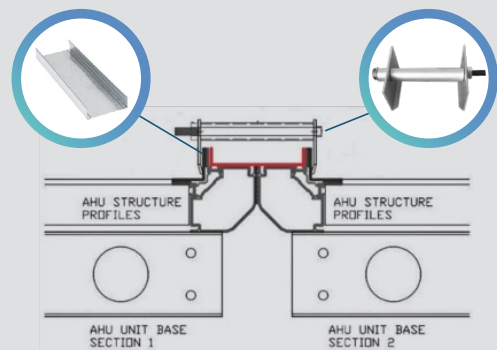

SERVICE LIGHTS



1. The AHU can be supplied with bulk headlight at the mixing box, filter, coil and the fan sections throughout.
2. The bulk head light is factory wired to comply with AS3000 via a conduit to the external outdoor IP rated switch.
3. All power supply wiring connections shall be properly terminated at the switch and all external conduits shall be sealed properly to ensure no air channelling through the conduit that might cause moisture condensation.
4. The bulk head lighting bulbs will be required to be checked regularly and replaced as necessary.
5. Marine grade IP rated service lights are available to suit your requirements.



PLATE HEAT EXCHANGER

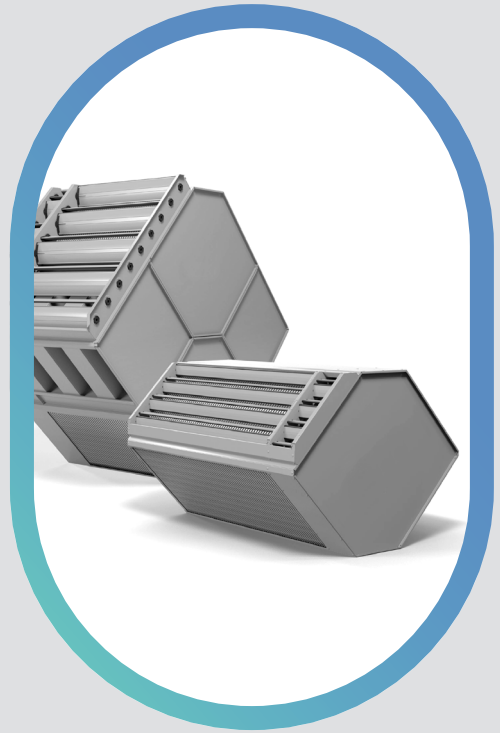

1. The exchanger package can be cleaned (Cleaning capability) as follows:
 - Remove dust and fibres with a soft brush or with a vacuum cleaner. Take care when cleaning with compressed air that the exchanger package is not damaged. Keep at a distance!
 - Oils, solvents, etc. can be removed with hot water or grease solvents, by washing or immersing. Cleaning with high-pressure devices is possible if:
 - Use of a flat nozzle 40°
 - Min. 20 cm distance between nozzle and exchanger
 - Max. water pressure is 100 bar
2. Sensible plate heat exchanger with efficiency up to 80%. Made by flat aluminium foils suitable for AC and industrial ventilation.
3. Enthalpy plate heat exchanger with efficiency up to 75%. Made by third generation paper, fire retardant and mould resistant.

OPTIONAL ACCESSORIES

Colair units may be supplied with optional accessories and may require the installing company to ensure all loose items remain with the unit.



UV rated viewing portholes



Magnehelic gauges and service lights



Heavy gauge hinges and lockable door handles



Extended stubs and additional insulation



VCD Actuator



Variable speed drive



Safety cage



Access door safety switch

UNIT IDENTIFICATION

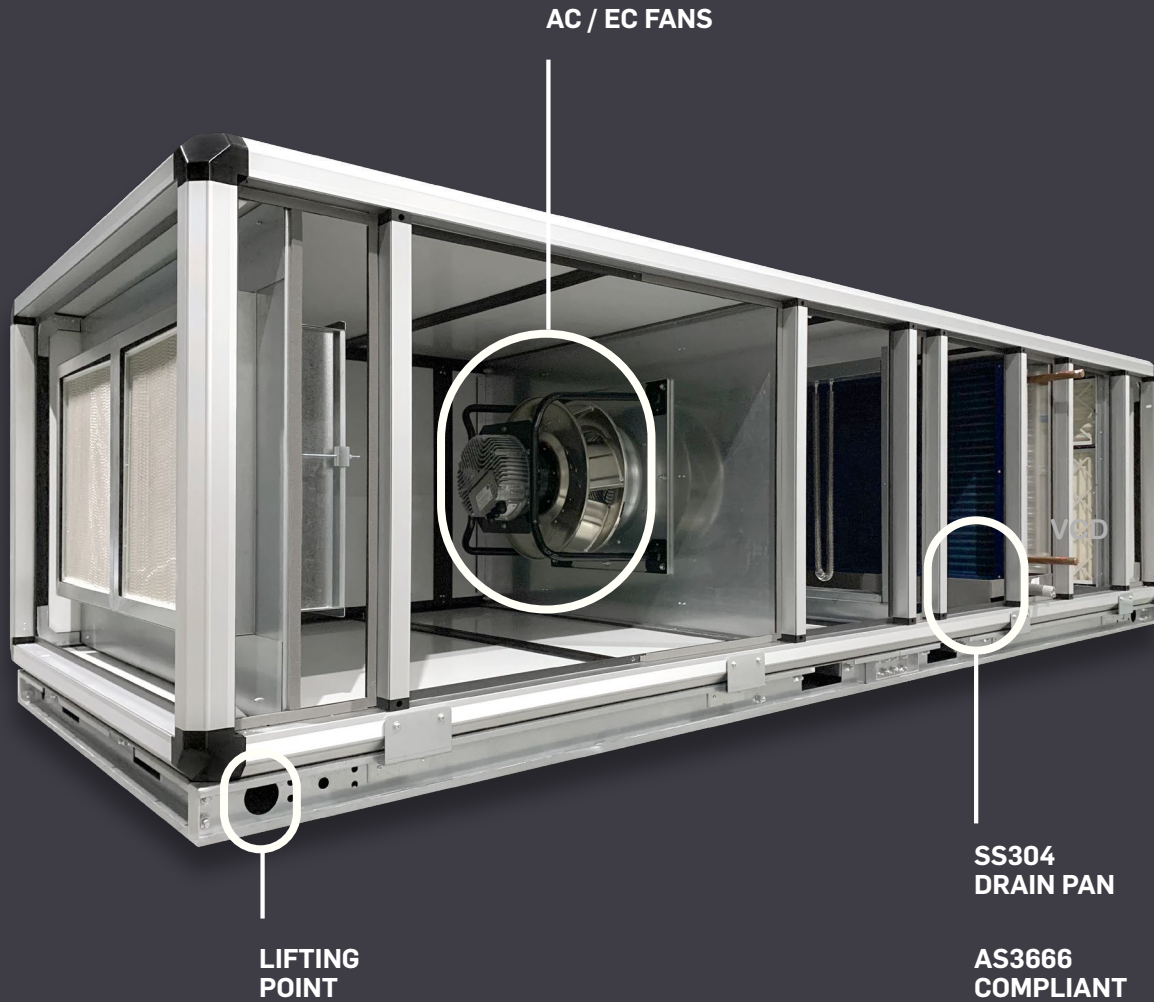

Each Colair unit is supplied with a self-adhesive identification label).
The label displays the following information:

- Serial number
- Unit model
- Fan supply air volume (l/s)
- Motor kW

The labels are located on the outside of the access door of each fan section. Any communication with the Colair Pty Ltd service department will require the corresponding serial number to be provided for identification of the Colair unit.



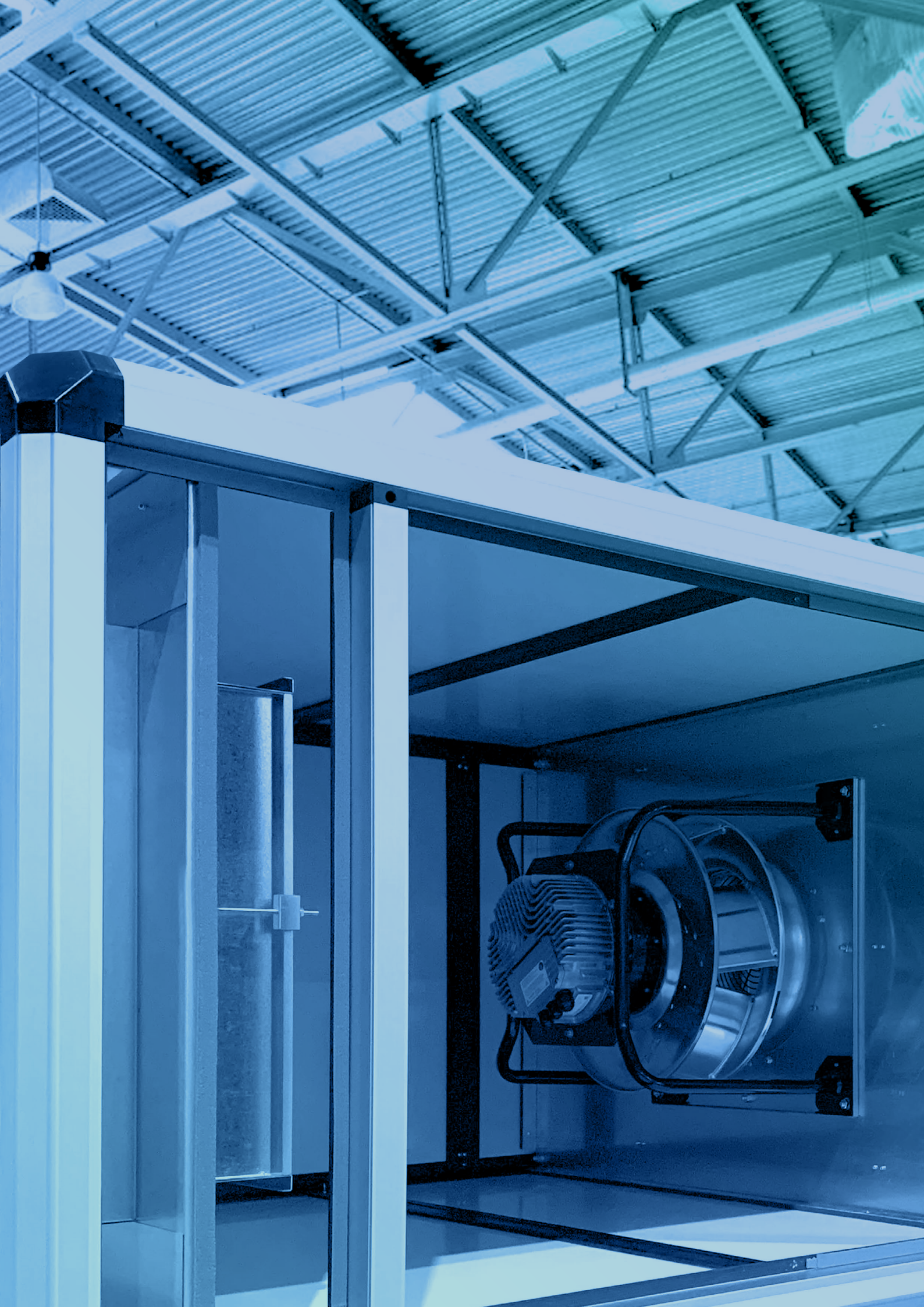

AHU CASE SIZING BY DESIGN AIR FLOW RATE

		Module Width											
		10	15	20	25	30	35	40	45	50	55	60	65
Module Height	Casing Size	795	1100	1405	1710	2015	2320	2625	2930	3235	3540	3845	4150
10	795	600	980	1370	1760	2150							
15	1100		1600	2230	2860	3490	4120						
20	1405			3090	3960	4830	5700	6570					
25	1710				4950	6040	7130	8220	9310				
30	2015					7380	8710	10040	11370	12700			
35	2320						10130	11680	13230	14780	16330	17880	19440

NOTES

1. Air flow rate listed is in l/s.
2. Air flow rate shown as maximum allowed based on 2.5m/s face velocity.
3. Casing size shown is in mm.
4. All models shown are able to fit into standard container of 20', 40' or 40'HC where applicable.
5. Unit height to add AHU metal base 100mm.
6. Unit height to add damper height 125mm where applicable.
7. Unit length to add damper depth 125mm where applicable.
8. Unit width with coil heat exchanger, coil pipe header extended out from side panel maximum 150mm.

AIR FILTER CONFIGURATION

		Module Width																							
		10		15		20		25		30		35		40		45		50		55		60		65	
		Full	Half	Full	Half	Full	Half	Full	Half	Full	Half	Full	Half	Full	Half	Full	Half	Full	Half	Full	Half	Full	Half	Full	Half
Module Height	10	1	0	1	1	2	0	2	1	3	0														
	15			1	2	2	2	2	3	3	3	3	4												
	20					4	0	4	2	6	0	6	2	8	0										
	25							4	4	6	3	6	5	8	4	8	6								
	30									9	0	9	3	12	0	12	3	15	0						
	35											9	6	12	4	12	7	15	5	15	8	18	6	18	9

NOTES

1. Full size filter dimension is nominal at 610mm (h) x 610mm (w).
2. Half size filter dimension is nominal at 305mm (h) x 610mm (w).
3. Standard pleated synthetic fibre filter class is G3, G4 and M5.
4. Thickness of aluminium casing is nominal 50mm.
5. Standard deepbed filter class is M6, F7, F8 and F9. Thickness of GI casing is nominal 25mm. Standard filter lengths of 380 and 530mm.
6. Filters can be either front loading or side loading as per requirement, selection or space availability.

COOLING PERFORMANCE DATASHEET @ 2.5M/S COIL FACE VELOCITY

Model No	Model	Unit Casing Measurement, mm		Air Flow, l/s @2.5m/s	Cooling Capacity, kW	Leaving Coil Temp DB, deg °C	Water Flow Rate, l/s	Water Pressure Drop, kPa	Pipe Connection Size OD, mm	Pipe Connection Size OD, mm
		Height	Width							
1	1010	795	795	600	14	10	12.4/11.9	0.57	32	34
2	1015	795	1100	980	25	17	12/11.6	0.97	30	42
3	1020	795	1405	1370	34	23	12.2/11.7	1.34	28	42
4	1025	795	1710	1760	43	30	12.2/11.8	1.71	32	42
5	1030	795	2015	2150	50	36	12.6/12.1	2.00	19	48
6	1515	1100	1100	1600	37	26	12.7/12.2	1.47	21	42
7	1520	1100	1405	2230	52	37	12.7/12.2	2.06	20	48
8	1525	1100	1710	2860	70	49	12.2/11.8	2.78	22	61
9	1530	1100	2015	3490	82	58	12.6/12.1	3.25	17	61
10	1535	1100	2320	4120	100	70	12.3/11.8	3.97	26	61
11	2020	1405	1405	3090	76	53	12.2/11.7	3.02	27	61
12	2025	1405	1710	3960	97	67	12.2/11.8	3.85	28	61
13	2030	1405	2015	4830	113	80	12.6/12.1	4.50	27	61
14	2035	1405	2320	5700	138	96	12.3/11.8	5.50	40	61
15	2040	1405	2625	6570	164	113	12.1/11.6	6.51	33	73
16	2525	1710	1710	4950	111	80	13/12.5	4.40	23	61
17	2530	1710	2015	6040	142	100	12.6/12.1	5.63	20	73
18	2535	1710	2320	7130	160	115	13/12.5	6.34	20	73
19	2540	1710	2625	8220	191	135	12.7/12.2	7.58	29	73
20	2545	1710	2930	9310	204	148	13.1/12.6	8.12	29	73
21	3030	2015	2015	7380	173	122	12.6/12.1	6.88	19	61
22	3035	2015	2320	8710	212	147	12.3/11.8	8.41	28	61
23	3040	2015	2625	10040	251	173	12.1/11.6	9.95	40	61
24	3045	2015	2930	11370	290	198	11.9/11.4	11.5	38	73
25	3050	2015	3235	12700	329	223	11.7/11.3	13.1	49	73
26	3535	2320	2320	10130	246	171	12.3/11.8	9.78	34	61
27	3540	2320	2625	11680	291	201	12.1/11.6	11.6	30	73
28	3545	2320	2930	13230	290	210	13.1/12.6	11.5	16	73
29	3550	2320	3235	14780	334	239	12.9/12.4	13.3	22	73
30	3555	2320	3540	16330	379	268	12.7/12.2	15.0	28	73
31	3560	2320	3845	17880	423	297	12.5/12	16.8	35	73
32	3565	2320	4150	19440	468	327	12.4/11.9	18.6	26	89

NOTES

- Cooling performance rated based on 6 rows coil 394 fins/m.
- Entering coil temperature. 26.0°C DB. 19.0°C WB.
- Coil face velocity 2.5m/s. Actual air pressure drop 190Pa.
- Chilled water in @ 6.0°C. Chilled water out @ 12.0°C.
- Chilled water pipe connection is brass type, BSPT male.
- Model 35XX comes with 2 coils stacked. Separate top and bottom coil header set.
- AHRI Standard 410 certified coil performance data.

COOLING PERFORMANCE DATASHEET @ 2.2M/S COIL FACE VELOCITY

Model No	Model	Unit Casing Measurement, mm		Air Flow, l/s @2.2m/s	Cooling Capacity, kW	Leaving Coil Temp DB, deg °C	Water Flow Rate, l/s	Water Pressure Drop, kPa	Pipe Connection Size OD, mm	Pipe Connection Size OD, mm
		Height	Width							
1	1010	795	795	530	13	9	12/11.6	0.52	26	34
2	1015	795	1100	870	23	15	11.7/11.3	0.89	32	34
3	1020	795	1405	1210	31	21	11.8/11.4	1.23	24	42
4	1025	795	1710	1550	39	27	11.8/11.4	1.56	27	42
5	1030	795	2015	1890	46	32	12.2/11.8	1.83	16	48
6	1515	1100	1100	1410	34	24	12.3/11.9	1.35	18	42
7	1520	1100	1405	1960	47	33	12.3/11.9	1.88	17	48
8	1525	1100	1710	2520	64	44	11.8/11.4	2.54	32	48
9	1530	1100	2015	3070	75	52	12.2/11.8	2.97	15	61
10	1535	1100	2320	3620	91	63	11.9/11.5	3.63	22	61
11	2020	1405	1405	2720	70	48	11.8/11.4	2.76	37	48
12	2025	1405	1710	3480	89	61	11.8/11.4	3.51	24	61
13	2030	1405	2015	4250	104	72	12.2/11.8	4.12	22	61
14	2035	1405	2320	5020	127	87	11.9/11.5	5.03	34	61
15	2040	1405	2625	5780	150	102	11.7/11.3	5.94	28	73
16	2525	1710	1710	4350	101	72	12.6/12.2	4.03	19	61
17	2530	1710	2015	5310	130	90	12.2/11.8	5.15	32	61
18	2535	1710	2320	6270	146	104	12.6/12.1	5.81	17	73
19	2540	1710	2625	7230	175	122	12.3/11.9	6.93	24	73
20	2545	1710	2930	8190	187	134	12.7/12.3	7.44	25	73
21	3030	2015	2015	6490	159	110	12.2/11.8	6.30	16	61
22	3035	2015	2320	7660	193	133	11.9/11.5	7.69	24	61
23	3040	2015	2625	8840	229	156	11.7/11.3	9.09	34	61
24	3045	2015	2930	10010	264	179	11.5/11.1	10.5	47	61
25	3050	2015	3235	11180	300	202	11.3/11	11.9	42	73
26	3535	2320	2320	8920	225	155	11.9/11.5	8.94	29	61
27	3540	2320	2625	10280	266	181	11.7/11.3	10.6	40	61
28	3545	2320	2930	11650	266	190	12.7/12.3	10.6	30	61
29	3550	2320	3235	13010	306	216	12.5/12.1	12.2	18	73
30	3555	2320	3540	14370	347	243	12.3/11.9	13.8	24	73
31	3560	2320	3845	15740	387	269	12.1/11.7	15.4	30	73
32	3565	2320	4150	17110	428	295	12/11.6	17.0	36	73

NOTES

- Cooling performance rated based on 6 rows coil 394 fins/m.
- Entering coil temperature. 26.0°C DB. 19.0°C WB.
- Coil face velocity 2.2m/s. Actual air pressure drop 190Pa.
- Chilled water in @ 6.0°C. Chilled water out @ 12.0°C.
- Chilled water pipe connection is brass type, BSPT male.
- Model 35XX comes with 2 coils stacked. Separate top and bottom coil header set.
- AHRI Standard 410 certified coil performance data.

HEATING PERFORMANCE DATASHEET @ 2.5M/S COIL FACE VELOCITY

Model No	Model	Unit Casing Measurement, mm		Air Flow, l/s @2.5m/s	Heating Capacity, kW	Leaving Coil Temp DB, deg°C	Water Flow Rate, l/s	Water Pressure Drop, kPa	Pipe Connection Size OD, mm
		Height	Width						
1	1010	795	795	600	8.9	24.2	0.15	29	22
2	1015	795	1100	980	14.5	24.1	0.24	24	22
3	1020	795	1405	1370	19.5	23.7	0.32	28	22
4	1025	795	1710	1760	25.7	24.0	0.42	15	34
5	1030	795	2015	2150	31.9	24.2	0.52	23	34
6	1515	1100	1100	1600	23.2	23.9	0.38	13	34
7	1520	1100	1405	2230	33.1	24.2	0.54	27	34
8	1525	1100	1710	2860	43.2	24.4	0.70	33	34
9	1530	1100	2015	3490	52.0	24.2	0.85	24	34
10	1535	1100	2320	4120	62.1	24.4	1.01	28	42
11	2020	1405	1405	3090	45.7	24.1	0.74	19	34
12	2025	1405	1710	3960	57.8	24.0	0.94	19	34
13	2030	1405	2015	4830	71.6	24.2	1.17	19	42
14	2035	1405	2320	5700	85.5	24.3	1.39	28	42
15	2040	1405	2625	6570	94.3	23.8	1.54	18	42
16	2525	1710	1710	4950	72.4	24.0	1.18	15	42
17	2530	1710	2015	6040	89.7	24.2	1.46	24	42
18	2535	1710	2320	7130	101.0	23.6	1.65	19	42
19	2540	1710	2625	8220	118.2	23.8	1.93	14	48
20	2545	1710	2930	9310	135.4	23.9	2.21	19	48
21	3030	2015	2015	7380	109.8	24.2	1.79	24	34
22	3035	2015	2320	8710	131.0	24.4	2.14	27	42
23	3040	2015	2625	10040	144.3	23.8	2.35	12	42
24	3045	2015	2930	11370	165.4	23.9	2.69	16	42
25	3050	2015	3235	12700	186.5	24.1	3.04	21	42
26	3535	2320	2320	10130	152.0	24.3	2.48	26	42
27	3540	2320	2625	11680	167.6	23.8	2.74	15	42
28	3545	2320	2930	13230	192.2	23.9	3.14	20	42
29	3550	2320	3235	14780	216.6	24.0	3.54	25	42
30	3555	2320	3540	16330	241.4	24.1	3.94	20	48
31	3560	2320	3845	17880	265.8	24.2	4.34	24	48
32	3565	2320	4150	19440	290.6	24.3	4.74	30	48

NOTES

1. Heating performance rated based on 1 row coil 394 fins/m.
2. Entering coil temperature. 12.0°C DB.
3. Coil face velocity 2.5m/s. Actual air pressure drop 15Pa.
4. Heating water in @ 80.0°C. Chilled water out @ 65.0°C.
5. Heating water pipe connection is brass type, BSPT male.
6. Model 35XX comes with 2 coils stacked. Separate top and bottom coil header set.
7. AHRI Standard 410 certified coil performance data.

HEATING PERFORMANCE DATASHEET @ 2.2M/S COIL FACE VELOCITY

Model No	Model	Unit Casing Measurement, mm		Air Flow, l/s @2.2m/s	Heating Capacity, kW	Leaving Coil Temp DB, deg°C	Water Flow Rate, l/s	Water Pressure Drop, kPa	Pipe Connection Size OD, mm
		Height	Width						
1	1010	795	795	530	8.2	24.9	0.13	24	22
2	1015	795	1100	870	13.4	24.7	0.22	21	22
3	1020	795	1405	1210	18.1	24.3	0.29	24	22
4	1025	795	1710	1550	23.7	24.6	0.39	12	34
5	1030	795	2015	1890	29.4	24.8	0.48	20	34
6	1515	1100	1100	1410	21.4	24.5	0.35	11	34
7	1520	1100	1405	1960	30.5	24.8	0.50	23	34
8	1525	1100	1710	2520	39.8	25.0	0.65	29	34
9	1530	1100	2015	3070	48.0	24.8	0.78	21	34
10	1535	1100	2320	3620	57.2	25.0	0.93	30	34
11	2020	1405	1405	2720	42.1	24.7	0.69	16	34
12	2025	1405	1710	3480	53.3	24.6	0.87	17	34
13	2030	1405	2015	4250	66.0	24.8	1.08	17	42
14	2035	1405	2320	5020	78.9	24.9	1.29	25	42
15	2040	1405	2625	5780	87.0	24.4	1.42	15	42
16	2525	1710	1710	4350	66.7	24.6	1.09	13	42
17	2530	1710	2015	5310	82.7	24.8	1.35	21	42
18	2535	1710	2320	6270	93.2	24.2	1.52	16	42
19	2540	1710	2625	7230	109.0	24.4	1.78	23	42
20	2545	1710	2930	8190	124.9	24.5	2.04	17	48
21	3030	2015	2015	6490	101.3	24.8	1.65	21	34
22	3035	2015	2320	7660	120.8	24.9	1.97	23	42
23	3040	2015	2625	8840	133.2	24.4	2.17	10	42
24	3045	2015	2930	10010	152.6	24.5	2.49	14	42
25	3050	2015	3235	11180	172.1	24.6	2.80	18	42
26	3535	2320	2320	8920	140.2	24.9	2.28	22	42
27	3540	2320	2625	10280	154.8	24.4	2.52	13	42
28	3545	2320	2930	11650	177.2	24.5	2.88	17	42
29	3550	2320	3235	13010	199.8	24.6	3.26	21	42
30	3555	2320	3540	14370	222.6	24.7	3.62	17	48
31	3560	2320	3845	15740	245.2	24.8	4.00	21	48
32	3565	2320	4150	17110	268.0	24.9	4.36	25	48

NOTES

1. Heating performance rated based on 1 row coil 394 fins/m.
2. Entering coil temperature. 12.0°C DB.
3. Coil face velocity 2.2m/s. Actual air pressure drop 12Pa.
4. Heating water in @ 80.0°C. Chilled water out @ 65.0°C.
5. Heating water pipe connection is brass type, BSPT male.
6. Model 35XX comes with 2 coils stacked. Separate top and bottom coil header set.
7. AHRI Standard 410 certified coil performance data.

SINGLE PHASE FAN WIRING

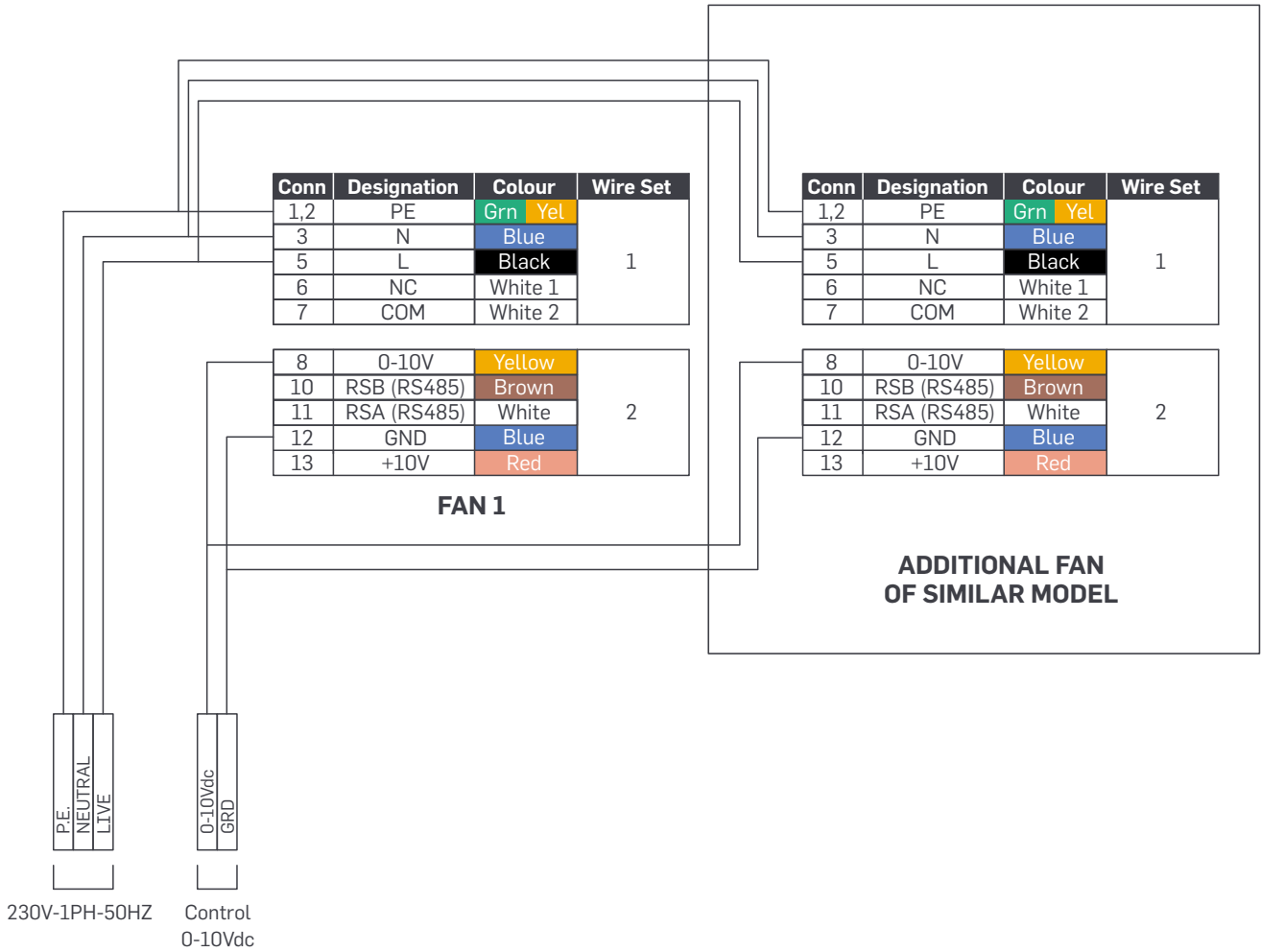

NOTES

1. Unit might come with 1 fan or multiple.
2. Unit complete pre-wired from fan to terminal box inside the unit.
3. Required minimum single phase power supply and 0-10Vdc signal for fan.
4. Conn. NC-COM is fan alarm signal (Optional to be wired to site BMS).
5. Conn. 10-11 is modbus connection (Optional to be wired to site BMS).
6. If no external 0-10Vdc from BMS, can connect 10K Ohm Potentiometer to Conn. 8, 13 and com for speed control.

THREE PHASE FAN WIRING

PROPOSED SITE WIRING

FACTORY WIRING TERMINATION

FAN SIDE LABEL

SERVICE LIGHT 240V/1PH/50HZ

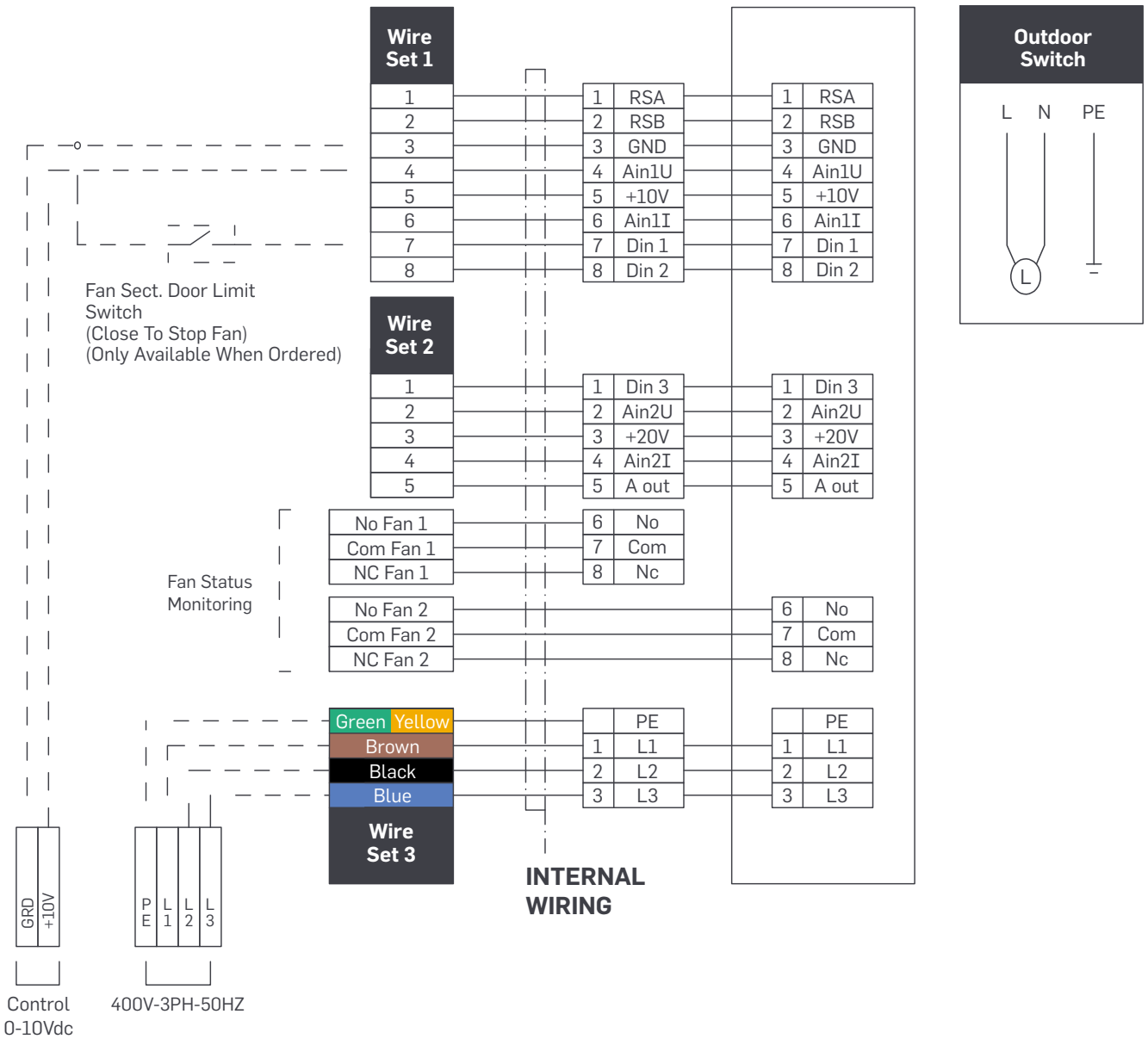

RECENT PROJECTS



Werribee Police



Holiday Inn



Kangan Tafe



Queen and Collins



Melbourne Uni
Student Precinct



COLAIR PTY LTD

97 Frankston Gardens Drive
Carrum Downs VIC 3201
Australia

P | 03 9763 1500
E | engineering@colair.net.au



COLAIR.NET.AU

AHD